

GRANDSTAND.

SEGA®

VIDEO FLIPPER

HOW TO PLAY

For 1 or 2 players

This game enables you through split second timing and excellent ball shooting strength control to rhythmically pursue your way around the playfield with extra balls being your reward for the high skill you display.

When playing by using the KEYBOARD (SC-3000)

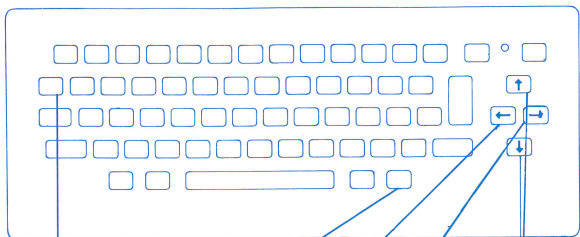

FUNC

START BUTTON
for 2 players

**INS
DEL**

START BUTTON
for 1 player

Left
Flipper

Right
Flipper

Ball Shooting
Adjustment

SHOOT BUTTON
(either one is
usable).

When playing by using the JOYSTICK

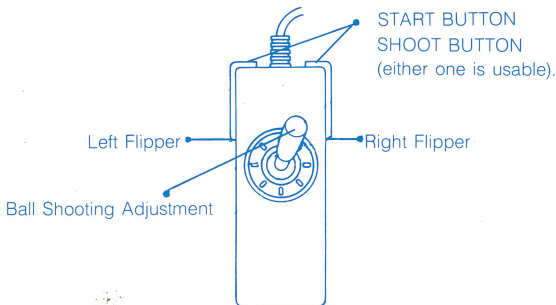

START BUTTON
SHOOT BUTTON
(either one is usable).

Left Flipper

Right Flipper

Ball Shooting Adjustment

VIDEO FLIPPER

HOW TO PLAY

- ★ When playing by using the JOYSTICK.
For 1 player, connect the JOYSTICK TO "JOY 1" and press the START button.
For 2 players, connect the JOYSTICK TO "JOY 1" and "JOY 2" and then press the START button of "JOY 2"
- ★ When playing by using the KEYBOARD (SC-3000), refer to the illustration.
- ★ Manoeuvre the shooter (plunger) through the use of the JOYSTICK or control keys and make the necessary strength adjustment when shooting the ball.
- ★ Press the flipper button and shoot the ball.
- ★ When all the D.T.'s (drop targets) of a same colour group are deleted, you earn 1,000 bonus points.
- ★ When all the 7 drop targets are deleted, an extra ball is earned.
- ★ When you pass through all of the three 300 point gates the bonus multiplication rate increases.
- ★ When the ball enters the K.H. (kicker hole), score is based on the bonus points x the multiplication rate.
- ★ When all five balls have been used, game play will be over.

SCORE

- 1 Kicker Hole
- 2 D.T. 200
Bonus 1,000
- 3 Flipper
- 4 Flipper
- 5 Multiplication rate
increases when three
Roll Over Switches are lit.
- 6 D.T. 200
Bonus 1,000
- 7 D.T. 200
Bonus 1,000
- 8 Kicker Hole
- 9 Roll Over Switch
- 10 Un-stable Bumper
- 11 Shooter

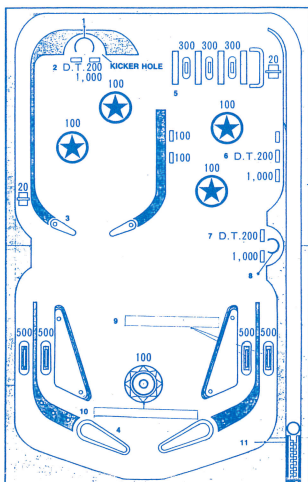

CAUTION:

This game is one of SEGA's original products. The sales of program contents by copying them without permission, whether partially or wholly, is strictly prohibited.

© SEGA 1983

GRANDSTAND LEISURE LTD.
P.O. Box 2353, Auckland, N.Z.

Made under licence in New Zealand to
SEGA ENTERPRISES LTD., TOKYO, JAPAN.